

Truss Technology IN BUILDING

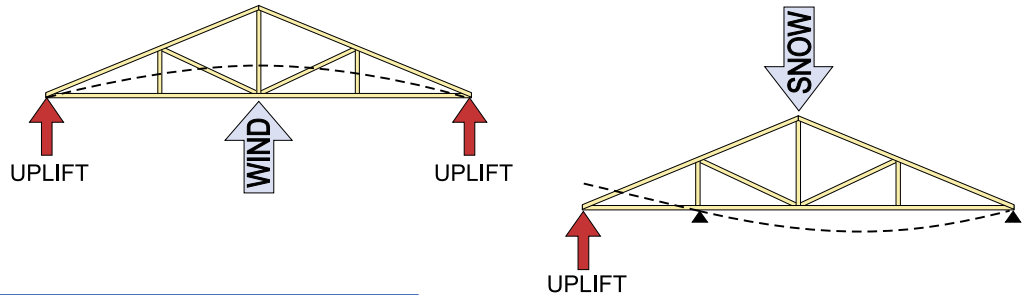

Toe-Nailing for Uplift Reactions

Conditions like wind loads or cantilevers can produce uplift reactions at truss bearing supports. When this is the case, the truss-to-bearing connection is required to resist the uplift reaction.



Wood trusses are commonly attached to the top plates of bearing walls using a toe-nailing detail like the one shown to the right. Is this toe-nailed connection sufficient? It depends, the uplift resistance of toe-nailed connections is governed by three factors:

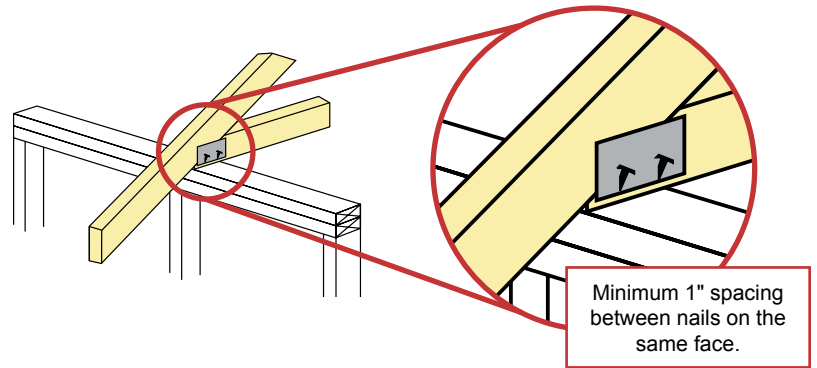

1. PROPER INSTALLATION OF TOE-NAILS

To get the most out of a toe-nailed connection, it is important to toe-nail correctly. The figure to the right illustrates proper toe-nailing. The dimensions shown are only meant to serve as a rough guide. Toe-nailing through truss plates does not affect the uplift capacity of the connection provided the truss plate is not damaged during installation.

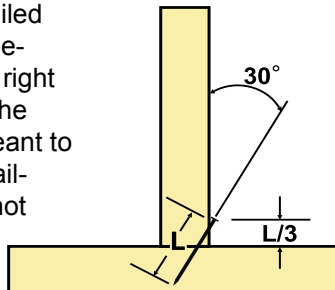

Graphic printed from the NDS® with permission of the AF&PA.

3. TYPE OF NAILS

The type of nail used in a toe-nailed connection also influences its uplift capacity. Some typical nails are shown below. When installing toe-nails, use care to avoid splitting the bottom chord lumber. The Building Designer should provide nail spacing and minimum end and edge distances. In lieu of such guidance, a rule-of-thumb is to limit the total number of toe-nails to three for a 2x4 top plate and five for 2x6 top plate.

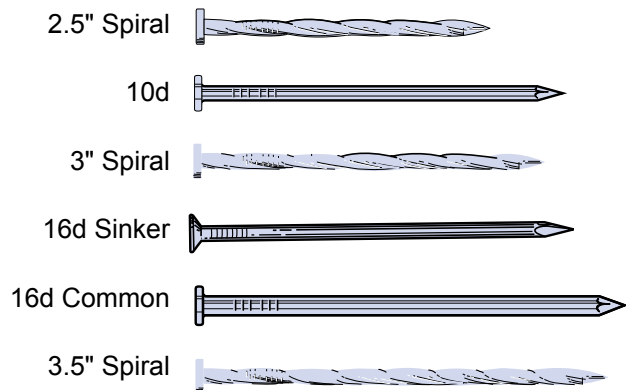

Above graphic printed with permission from Simpson Strong Tie Company.

2. GRADE & SPECIES OF TOP PLATE LUMBER

The grade and species of the top plate also affect the amount of uplift resistance obtained from a toe-nailed connection. For example, a toe-nailed connection using a Southern Pine top plate will provide greater resistance than the same connection using a Spruce-Pine-Fir top plate.

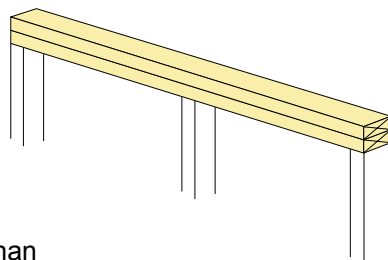

IS TOE-NAILING ENOUGH?

Use this table to estimate the uplift capacity of a toe-nailed connection. For example, three 16d common nails toe-nailed into a Southern Pine top plate will provide 216 lb (3 x 72 lb) of nominal uplift resistance. For wind load cases, multiply the nominal uplift by the wind load duration factor as described in footnote 1 of the table. This factored uplift resistance for the toe-nailed connection must be equal to or greater than the uplift reaction listed on the Truss Design Drawing. See Sample Truss Design Drawing.

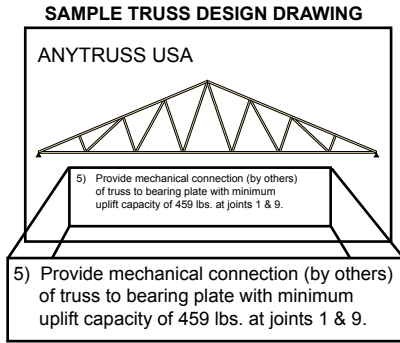

NAIL TYPE	VALUES FOR TOP PLATE SPECIES			
	SP*	DF-L*	HF*	S-P-F*
16d Common (0.162" x 3.5")	72.0	56.7	38.9	36.7
16d Box (0.135" x 3.5")	60.0	47.3	32.4	30.6
12d Common (0.148" x 3.25")	61.1	48.1	33.0	31.1
12d Box (0.128" x 3.25")	52.8	41.6	28.5	26.9

- Nominal design values shall be multiplied by all applicable adjustment factors to determine allowable design values per NDS®.
- Uplift capacities for pneumatically driven nails are similar to box nails of the same length and diameter.
- For nail capacities not shown here, consult a design professional.
- Values are based on the species of the top plate or the lesser of the species.

*SP: Southern Pine *DF-L: Douglas Fir Larch *HF: Hemlock-Fir *S-P-F: Spruce-Pine-Fir

MECHANICAL UPLIFT CONNECTIONS

If the toe-nail uplift resistance is less than the uplift reaction on the Truss Design Drawing, it is necessary to use a mechanical uplift connection like those shown here.

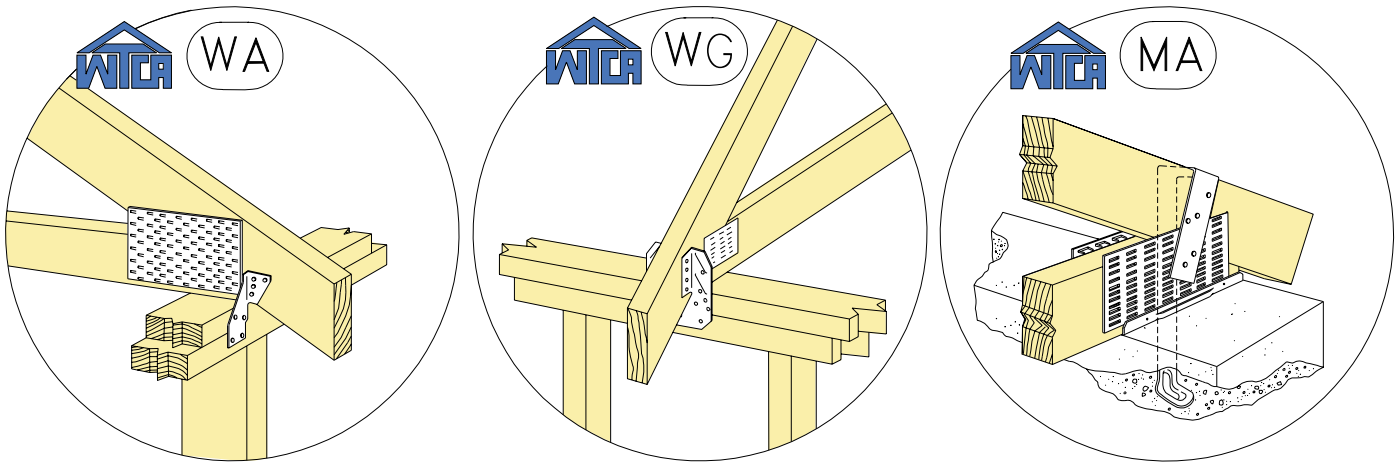

Under industry guidelines, trusses that have been field altered on the jobsite or overloaded during the installation phase of construction may null or void your truss manufacturer's limited warranty. Check your truss manufacturer's limited warranty for specific information.

Wood Truss Council of America

One WTCA Center

6300 Enterprise Lane • Madison, WI 53719

608/274-4849 • 608/274-3329 fax

www.woodtruss.com • wtca@woodtruss.com



An informational series designed to address the issues and questions faced by professionals in the building construction process.

Copyright © 2002, 2003 Wood Truss Council of America, Inc. All Rights Reserved.

Reproduction of this document, in any form, is prohibited without written permission from WTCA. This document should appear in more than one color.